



WACO[®] **BLUE**

**SCAFFOLDING
SYSTEM**



The Best Scaffolding In America

WACO[®]
Scaffolding & Equipment



WACO® BLUE SCAFFOLDING SYSTEM

FLOATING PINS This design allows one frame leg at a time to be placed over the connecting pin rather than wrestling the frame to align both legs at once. They add to the speed and safety of erecting WACO® Blue Frames. The pins have shoulders to maintain accurate alignment once in position.

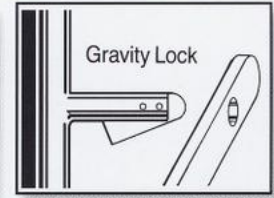

WACO® BLUE FRAMES

All WACO® Blue frames are five feet in width and come equipped with coupling pins.

The Walk Thru frames are five feet wide with a six foot vertical clearance for passageway and straddling objects.

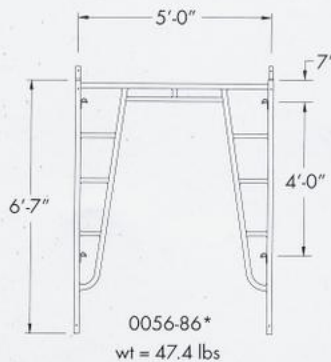
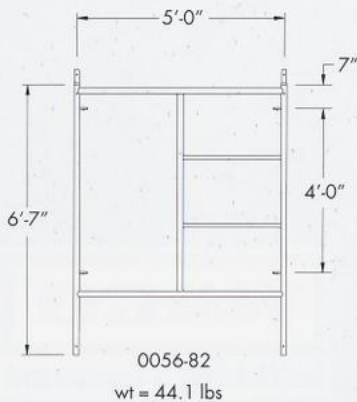
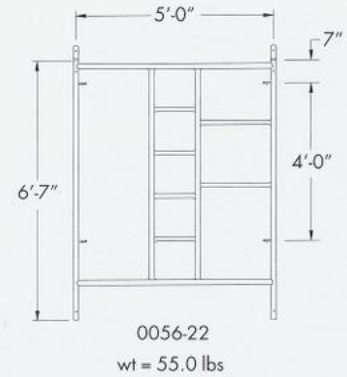
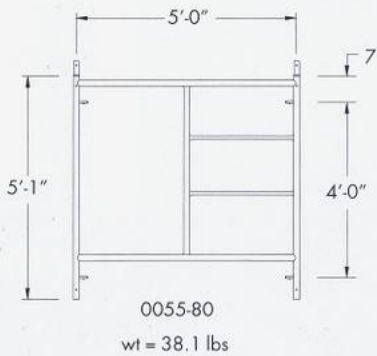
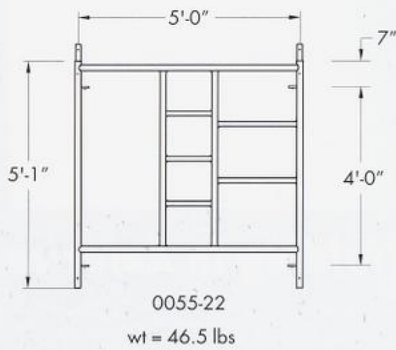
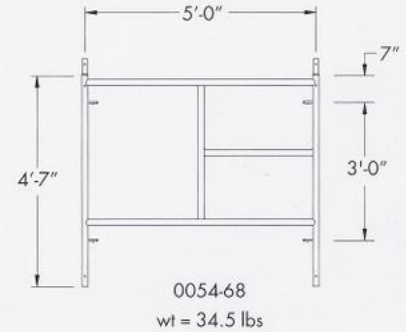
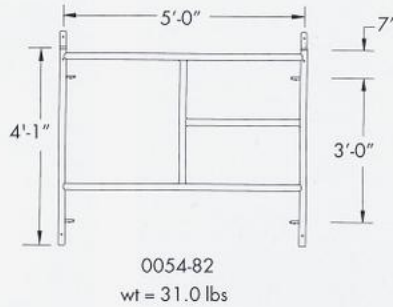
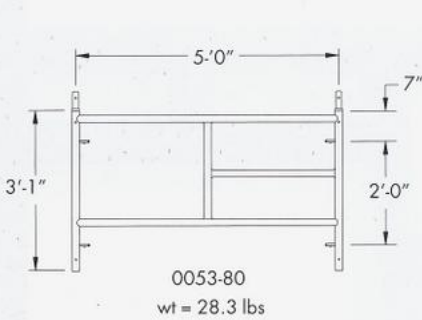

*Note: Speedlock®/Not Gravity locks



GRAVITY LOCK The Gravity lock has a pivoting metal tab in the center of the pin. This allows the cross brace to slide onto the pin and drop into locking position once the brace is past the tab. To dismantle the frame, the tab is manually raised with one hand while sliding the cross brace off with the other hand. Gravity Locks are standard on Waco® Blue frames.

WACO® BLUE ACCESSORIES

BASE PLATES & ADJUSTING SCREWS

Base Plate 0300-00

5" x 5" base plate with stem.
1.8 lbs.

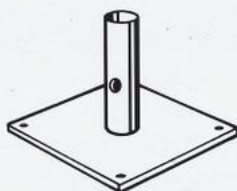

Tubular Adjusting Screw 0036-00

26" Tubular adjusting screw. Has 18" screw adjustment with socket. Used with caster or base plate.
10.7 lbs.



Tubular Adjusting Screw 0035-18

24" Adjusting screw with 18" screw adjustment and base plate. 10.7 lbs.

CASTER

For use with rolling towers. Heavy duty swivel and wheel locks.

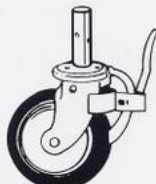

Model	Length	Weight
0318-04	8"	11 lb.

GUARD POSTS & RAILS



Guard rails attach to guard posts. Guard rail post slips into top of leg of end frame. Required for scaffolding.

Guard Rail Post 10 lb. Model 0032-00



Guard Rail

Model Number	Size	Weight (lbs)
0325-05	5'	4.8
0325-55	5' W/Keyhole	4.7
0327-07	7'	7.2
0328-08	8'	8.1
0033-10	10'	10.5

Note: Keyhole rail used above frame at midrail only

OPTIONAL LOCK SYSTEMS

0100-00-70
SpeedLock®



SIDE BRACKETS

Connects to frames at any level where there is a horizontal member.

Model	Size	Weight
0332-20	20" wide	11 lb.
0332-00	23" wide	11 lb.
0336-00	20" wide	9.1 lb.

ANGLE IRON CROSS BRACES

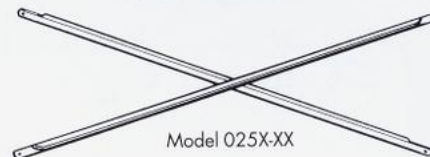

Model 025X-XX

Model Number	Size	Weight (lbs)
0253-07	2' x 7'	15.9
0253-08	2' x 8'	17.1
0254-07	3' x 7'	16.7
0254-08	3' x 8'	17.7
0255-07	4' x 7'	17.5
0255-08	4' x 8'	18.5

GALVANIZED TUBULAR CROSS BRACES

Model Number	Size	Weight (lbs)
0052-07	2' x 7'	11.4
0052-08	2' x 8'	12.5
0053-10	2' x 10'	13.3
0053-07	3' x 7'	11.9
0053-08	3' x 8'	14.6
0054-10	3' x 10'	16.0
0055-07	4' x 7'	12.0
0055-08	4' x 8'	16.7
0055-10	4' x 10'	18.7



HORIZONTAL BRACE

Provides additional rigidity in towers.

Model	Length	Weight
0026-07	7 ft.	6.5 lb.
0026-10	10 ft.	11 lb.

SCAFFOLDING GUIDELINES

SAFETY GUIDELINES

as recommended by SCAFFOLDING, SHORING & FORMING INSTITUTE

It shall be the responsibility of all employers and employees to read and comply with the following common sense guidelines which are designed to promote safety in the erecting and dismantling of scaffolds. These guidelines do not purport to be all-inclusive nor to supplant or replace other additional safety and precautionary measures to cover usual or unusual conditions. Local, State, or Federal statute or regulations shall supersede these guidelines if there is a conflict and it is the responsibility of each employee to comply.

GENERAL GUIDELINES

POST THESE SCAFFOLDING SAFETY GUIDELINES in a conspicuous place and be sure that all persons who erect, dismantle or use scaffolding are aware of them.

FOLLOW ALL STATE, LOCAL AND FEDERAL CODES, ORDINANCES AND REGULATIONS pertaining to scaffolding because they may be more restrictive. For example, height or width requirements may vary.

SURVEY THE JOB SITE — A survey shall be made of the job site for hazards, such as untamped earth fills, ditches, debris, high tension wires, unguarded openings, and other hazardous conditions created by other trades. These conditions shall be corrected or avoided as noted in the following sections.

INSPECT ALL EQUIPMENT BEFORE USING — Never use any equipment that is damaged or defective in any way.

KEEP ALL EQUIPMENT IN GOOD REPAIR — Avoid using corroded equipment — the strength of corroded equipment is not known.

INSPECT ERECTED SCAFFOLDS DAILY — or at the beginning of every shift to be sure that they are maintained in safe condition.

NEVER USE EQUIPMENT FOR PURPOSES OR IN WAYS FOR WHICH IT WAS NOT INTENDED.

REPORT ANY UNSAFE CONDITION. NEVER TAKE CHANCES — Do not work on scaffolds if your physical condition is such that you feel dizzy or unsteady in any way.

WORKING UNDER THE INFLUENCE OF ALCOHOL OR ILLEGAL DRUGS IS STRICTLY PROHIBITED.

CONSULT YOUR SCAFFOLDING SUPPLIER — NEVER TAKE CHANCES — Consult manuals and instructions provided by the supplier; scaffolding is his business.

GUIDELINES FOR ERECTION AND USE OF SCAFFOLDS

A. PROVIDE ADEQUATE SILLS for scaffold posts and use base plates.

B. USE ADJUSTING SCREWS or other approved conditions.

C. PLUMB AND LEVEL ALL SCAFFOLDS as the erection proceeds. Do not force braces to fit—level the scaffold until proper fit can be made easily.

D. BRACING Each frame or panel shall be braced by horizontal bracing. Cross bracing, diagonal bracing or any combination thereof for securing vertical members together laterally. All brace connections shall be made secure, in accordance with manufacturers' recommendations.

E. DO NOT CLIMB CROSS BRACES Use only an access (climbing) ladder, access steps, frame designed to be climbed or equivalent safe access to the scaffold.

F. TIE RUNNING SCAFFOLD TO WALL or structure when the height exceeds four (4) times the minimum scaffold base dimension. The first vertical and longitudinal tie shall be placed at this point. Vertical ties shall be repeated at intervals not greater than 26 feet. Longitudinal ties shall be placed at each end and at intervals

not greater than 30 feet. Ties must prevent the scaffold from tipping into or away from the wall or structure.

G. WHEN SCAFFOLDS ARE TO BE PARTIALLY OR FULLY ENCLOSED, specific precautions must be taken to assure frequency and adequacy of ties attaching the scaffolding to the building due to increased load conditions resulting from effects of wind and weather. The scaffolding components to which the ties are attached must also be checked for additional loads.

H. WHEN FREE STANDING SCAFFOLD TOWERS exceed four times their minimum base dimension vertically, they must be restrained from tipping.

I. DO NOT ERECT SCAFFOLDS NEAR ELECTRICAL POWER LINES unless proper precautions are taken. Consult the power service company for advice.

J. DO NOT USE LADDERS or makeshift devices on top of scaffolds to increase the height.

K. DO NOT EXCEED MANUFACTURERS' RECOMMENDED LOAD RATING.

L. EQUIP AND MAINTAIN ALL PLATFORMS with proper guardrails, midrails and toeboards along all open sides and ends of scaffold platforms.

M. ALL BRACKETS shall be seated correctly with side brackets parallel to the frames and end brackets at 90 degrees to the frames. Brackets shall not be bent or twisted from normal position. Brackets (except mobile brackets designed to carry materials) are to be used as work platforms only and shall not be used for storage of material or equipment. When brackets are used, the scaffold shall be tied to the structure or otherwise restrained to prevent tipping.

N. ALL SCAFFOLDING ACCESSORIES shall be used and installed in accordance with the manufacturers' recommended procedure. Accessories shall not be altered in the field. Scaffolds, frames and their components of various manufacturers shall not be intermixed.

O. FOR PLANKING, THE FOLLOWING GUIDELINES APPLY:

1. Use only lumber that is properly inspected and graded as scaffold plank.



SCAFFOLDING

Standard End Frames
Walk Thru Frames
Wedgelok™ System
FasTube®
Exprescaff®

SPECIALTY TRADE TOOLS

Mason's T-Jacks
Chimney Scaffolds
Mortar Board Stands
Sheet Material Dollies
Speed-Scaff™
Casters
Trash Chutes

SHORING

Post Shores
Hi-Load® Frames
Shore "X"® Frames
Shore "X"® 25 Kip frames
Aluminum Joists
WacoMax®

FORMING

Modular Forms
Magnum® Large Panel Forms
Aluminum Gang Forms
Heavy Duty Wall Ties
Wacote® Form Oil
Concrete Accessories

SCAFFOLDING GUIDELINES *continued*

2. Planking shall have at least 12 inches of overlap and extend 6 inches beyond center of support, or be cleated at both ends to prevent sliding off supports.
 3. Fabricated scaffold planks and platforms, unless created or restrained by hooks, shall extend over their end supports not less than 6 inches nor more than 12 inches.
 4. Secure plank to scaffold when necessary.
- P. FOR ROLLING SCAFFOLDS THE FOLLOWING ADDITIONAL GUIDELINES APPLY:**
1. CASTERS WITH PLAIN STEMS shall be attached to the panel or adjustment screw by pins or other suitable means.
 2. DO NOT EXTEND ADJUSTING SCREWS ON ROLLING SCAFFOLDS MORE THAN 12 INCHES.
 3. WHEELS OR CASTERS shall be provided with a locking device and kept locked during erection and dismantling or any time scaffolds are not being moved.
 4. SECURE OR REMOVE ALL MATERIAL AND EQUIPMENT from platform before moving scaffold.
 5. USE HORIZONTAL DIAGONAL BRACING near the bottom and at 20 foot intervals measured from the rolling surface.
 6. DO NOT USE brackets or other platform extensions without consideration of overturning effect.
 7. THE HEIGHT OF A ROLLING SCAFFOLD excluding its uppermost guardrails, must not exceed four times its smallest base dimension unless it is stabilized by an engineered counterweight system or some other equivalent means.
 8. CLEAT OR SECURE ALL PLANKS.
 9. DO NOT ATTEMPT TO MOVE A ROLLING SCAFFOLD WITHOUT SUFFICIENT HELP — watch out for holes in floor and overhead obstructions — stabilize against tipping.
 10. DO NOT RIDE ROLLING SCAFFOLDS.
 11. JOINTS shall be restrained from separation
- Q. FOR "PUTLOGS" AND "TRUSSES" THE FOLLOWING ADDITIONAL GUIDELINES APPLY:**
1. DO NOT CANTILEVER OR EXTEND PUTLOGS/TRUSSES as side brackets without thorough consideration for loads to be applied.
 2. PUTLOGS/TRUSSES SHOULD BE EXTENDED AT LEAST 6 inches beyond point of support.
 3. PLACE RECOMMENDED BRACING BETWEEN PUTLOGS/TRUSSES when the span of putlog/truss is more than 12 feet.
- R. WHEN DISMANTLING SCAFFOLDING THE FOLLOWING ADDITIONAL GUIDELINES APPLY:**
1. CHECK TO SEE IF SCAFFOLDING HAS BEEN STRUCTURALLY ALTERED in any way which would make it unsafe, and if so, reconstruct where necessary before commencing with dismantling procedures.
 2. VISUALLY INSPECT PLANK prior to dismantling to be sure that they are safe to work on.
 3. COMPONENTS SHOULD BE LOWERED as soon as dismantled in a safe manner so as to protect personnel below.
 4. DO NOT ACCUMULATE EXCESS COMPONENTS OR EQUIPMENT on the level being dismantled.
 5. DISMANTLED EQUIPMENT should be stockpiled in an orderly manner.
- S. FOLLOW ERECTION PROCEDURES AND USE MANUALS.**



Scaffolding & Equipment

Rentals Sales Erection

WARNING

Before using, putting up or taking down scaffolding or shoring check with your boss as to its safe use. There are many ways you can be hurt or killed using scaffolding. Use all equipment in accordance with safety design requirements and standards.

SAFETY MUST COME FIRST!

Branch	Hotline	Fax
Dealer Sales	(800) 321-3150	(216) 267-9562
Akron, OH	(800) 676-9226	(330) 785-3921
Atlantic City, NJ	(800) 273-1056	(609) 646-7808
Canton, OH	(800) 927-9226	(330) 497-0572
Carson, CA	(800) 251-4503	(310) 538-1003
Charleston, WV	(800) 678-9226	(304) 744-0349
Cincinnati, OH	(513) 829-4757	(513) 829-4749
Cleveland, OH	(800) 927-7502	(216) 351-9009
Columbus, OH	(800) 736-9226	(614) 922-0401
Indianapolis, IN	(888) 284-8744	(317) 951-8715
Minneapolis, MN	(800) 347-9356	(651) 697-0254
Phoenix, AZ	(888) 345-9226	(480) 507-8844
Pittsburgh, PA	(800) 422-9284	(412) 823-4840
San Diego, CA	(800) 734-9226	(858) 566-5780
San Diego Shipyard	(888) 472-2336	(619) 233-0802
Seattle, WA	(866) 642-8216	(206) 935-1702
Youngstown, OH	(888) 415-9737	(330) 792-2265

Corporate Office
4545 Spring Road
P.O. Box 318028
Cleveland, Ohio 44131-8028

800-321-3150

Visit Our Web Site
www.wacoscaf.com

